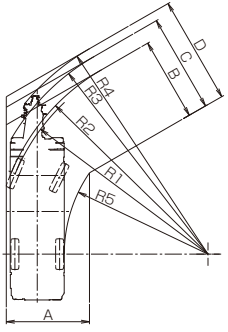
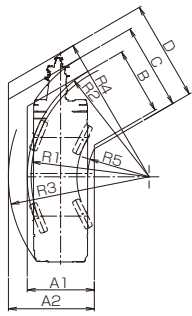
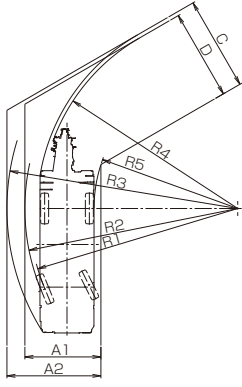
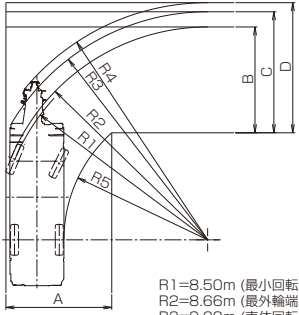
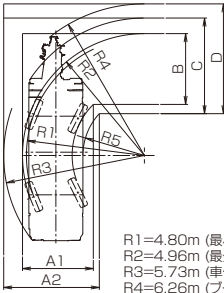
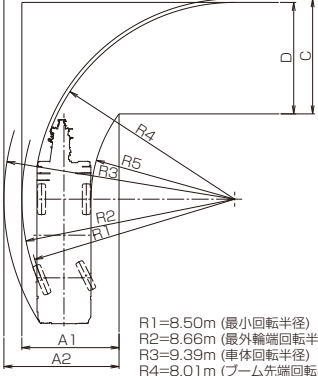
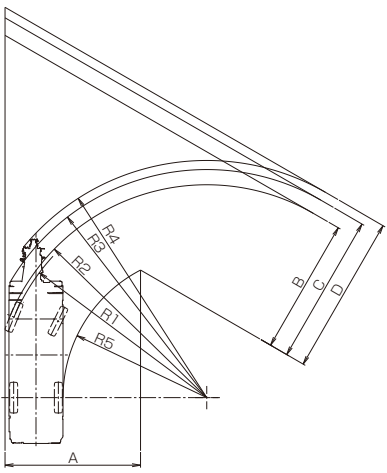
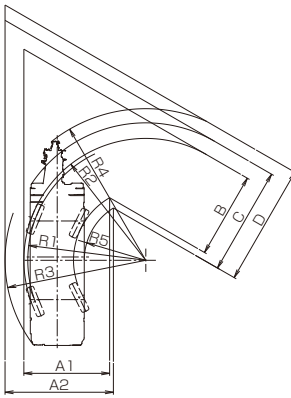
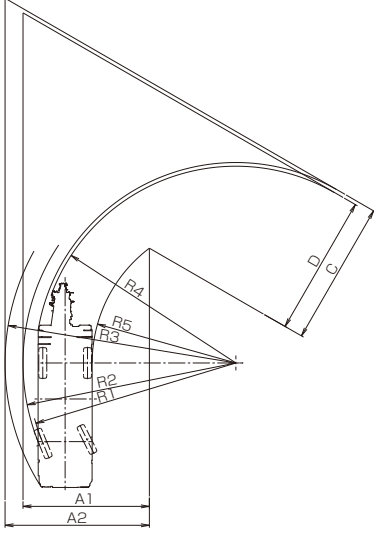

■最小通路幅 (60°、90°、120°)

(注)数値は計算値です。

	前2輪ステアリングで右折する場合	4輪ステアリングで右折する場合	後2輪ステアリングで右折する場合
60°	 <p>R1=8.50m (最小回転半径) R2=8.66m (最外輪端回転半径) R3=9.28m (車体回転半径) R4=9.70m (ブーム先端回転半径) R5=5.85m (車体内側回転半径)</p> <p>A=3.39m (入口通路幅) B=3.39m (車輪出口通路幅) C=4.00m (車体出口通路幅) D=4.37m (ブーム先端出口通路幅)</p>	 <p>R1=4.80m (最小回転半径) R2=4.96m (最外輪端回転半径) R3=5.73m (車体回転半径) R4=6.26m (ブーム先端回転半径) R5=2.50m (車体内側回転半径)</p> <p>A1=2.73m (車輪入口通路幅) A2=3.50m (車体入口通路幅) B=2.73m (車輪出口通路幅) C=3.50m (車体出口通路幅) D=4.07m (ブーム先端出口通路幅)</p>	 <p>R1=8.50m (最小回転半径) R2=8.66m (最外輪端回転半径) R3=9.39m (車体回転半径) R4=8.01m (ブーム先端回転半径) R5=5.85m (車体内側回転半径)</p> <p>A1=3.09m (車輪入口通路幅) A2=3.82m (車体入口通路幅) C=3.82m (車体出口通路幅) D=3.68m (ブーム先端出口通路幅)</p>
90°	 <p>R1=8.50m (最小回転半径) R2=8.66m (最外輪端回転半径) R3=9.28m (車体回転半径) R4=9.70m (ブーム先端回転半径) R5=5.85m (車体内側回転半径)</p> <p>A=4.30m (入口通路幅) B=4.30m (車輪出口通路幅) C=4.92m (車体出口通路幅) D=5.35m (ブーム先端出口通路幅)</p>	 <p>R1=4.80m (最小回転半径) R2=4.96m (最外輪端回転半径) R3=5.73m (車体回転半径) R4=6.26m (ブーム先端回転半径) R5=2.50m (車体内側回転半径)</p> <p>A1=2.88m (車輪入口通路幅) A2=3.89m (車体入口通路幅) B=2.88m (車輪出口通路幅) C=3.89m (車体出口通路幅) D=4.49m (ブーム先端出口通路幅)</p>	 <p>R1=8.50m (最小回転半径) R2=8.66m (最外輪端回転半径) R3=9.39m (車体回転半径) R4=8.01m (ブーム先端回転半径) R5=5.85m (車体内側回転半径)</p> <p>A1=3.96m (車輪入口通路幅) A2=4.69m (車体入口通路幅) C=4.69m (車体出口通路幅) D=4.56m (ブーム先端出口通路幅)</p>
120°	 <p>R1=8.50m (最小回転半径) R2=8.66m (最外輪端回転半径) R3=9.28m (車体回転半径) R4=9.70m (ブーム先端回転半径) R5=5.85m (車体内側回転半径)</p> <p>A=5.51m (入口通路幅) B=5.51m (車輪出口通路幅) C=6.13m (車体出口通路幅) D=6.50m (ブーム先端出口通路幅)</p>	 <p>R1=4.80m (最小回転半径) R2=4.96m (最外輪端回転半径) R3=5.73m (車体回転半径) R4=6.26m (ブーム先端回転半径) R5=2.50m (車体内側回転半径)</p> <p>A1=3.49m (車輪入口通路幅) A2=4.41m (車体入口通路幅) B=3.49m (車輪出口通路幅) C=4.41m (車体出口通路幅) D=4.95m (ブーム先端出口通路幅)</p>	 <p>R1=8.50m (最小回転半径) R2=8.66m (最外輪端回転半径) R3=9.39m (車体回転半径) R4=8.01m (ブーム先端回転半径) R5=5.85m (車体内側回転半径)</p> <p>A1=5.14m (車輪入口通路幅) A2=5.87m (車体入口通路幅) C=5.87m (車体出口通路幅) D=5.72m (ブーム先端出口通路幅)</p>